



GRIZZLE™

GRIZZLE™ **EV Charger**

DUO

User Manual & Installation Guide





Grizzl-E Duo Manual v.5.7

Model Numbers:

GCD-14-24-P

GCD-6-24-P



Grizzl-E Duo Home EV Charging Station

The Grizzl-E Duo is the dual Electric Vehicle Charging Station solution built from the proven Grizzl-E design. Grizzl-E Duo has intelligent power sharing capability to provide up to 10kW of power to two vehicles simultaneously.

The Grizzl-E Duo comes exclusively with two 24ft Premium output cables. Internal design and components of the charger have been selected to provide maximum operational life of the device and be able to withstand the elements.

IMPORTANT SAFETY INSTRUCTIONS

This document contains instructions and warnings that must be followed when installing and using the Grizzl-E Duo Electric Vehicle Supply Equipment (EVSE). Before installing or using the EVSE, read this document including any WARNING and CAUTION symbols.

The Symbols Used Have the Following Meanings



Warning: risk of personal injury



Warning: risk of fire



Warning: risk of electric shock



Caution: risk of damage to equipment

- This document provides instructions for the charging station and should not be used for any other product. Before installation or use of this product, review this manual carefully and consult with a licensed contractor, licensed electrician, or trained installation expert to ensure compliance with local building codes and safety standards.
- Consult a licensed electrician to ensure that you can safely install and use this product.
- Ensure that the materials used, and the installation procedures, follow local building codes and safety standards.
- Do not attempt to disassemble or alter the unit in any way not specified in this manual.
- The information provided in this manual in no way exempts the user of responsibility to follow all applicable codes or safety standards.

Basic precautions should always be followed when using electrical products, including the following:

- Read all the instructions before using this product.
- Children should not use this device.
- Do not put fingers into the EV connector.
- Do not touch live electrical parts.
- Do not use this product if the flexible power cord or EV cable is ragged, has broken insulation, or any other signs of damage.
- Do not use this product if the enclosure or the EV connector is broken, cracked, open, or shows any other indication of damage.
- To avoid a risk of fire or electric shock, do not use this device with an extension cord or electrical adapter.
- Improper connection of the equipment grounding conductor can result in a risk of electric shock. Check with a licensed electrician if you are in doubt as to whether the product is properly connected and grounded.

Repair and Maintenance Clause

- All United Chargers products do not require routine maintenance however, periodic inspections should be conducted to ensure that all parts remain in good working order and no damage exists.
- Do not attempt to disassemble, repair, tamper with, or modify any components of the product in any way not specified in this manual.
- Contact United Chargers for any errors or technical support issues.



WARNING: This equipment is intended only for charging vehicles that do not require ventilation during charging. Please refer to your vehicle's owner's manual to determine ventilation requirements.



Product Features

GRIZZL-E™ Duo Electric Vehicle Charging Station (EVSE)

- J1772 AC Level 2 (208-240 VAC),
- Two charging connectors. Can charge two vehicles at the same time.
- Adjustable Maximum Current Output (40A, 32A, 24A, 16A) to Support Multiple Circuit Ratings (50A, 40A, 30A, 20A)
- Extreme Duty, Rigid & Compact Design:
- Robust and heavy-duty aluminum cast case; airtight enclosure for indoor or outdoor use
- EasyEvPlug™ Holster or Tesla EasyEVPlug™ Holster with cable Management System.
- Plug-in Configuration for easy portability.
- Wall Mount with security features (including single stud mount), Pedestal, Bollard/Pole (Single & Dual Port) available from United Chargers.

Adjustable Maximum Current Output to Support Multiple Circuit Ratings

The GRIZZL-E™ Electric Vehicle Charging Station features the ability to adjust the maximum charging station current output to allow the use of a 50A, 40A, 30A, or 20A Dedicated Circuit as follows:

50A Circuit Rating:	To support 40A (9.60kW) Maximum Charging Station Output
40A Circuit Rating:	To support 32A (7.68kW) Maximum Charging Station Output
30A Circuit Rating:	To support 24A (5.76kW) Maximum Charging Station Output
20A Circuit Rating:	To support 16A (3.84kW) Maximum Charging Station Output

The Default Factory Setting is 40A (9.6kW). To change the maximum current output, refer to Chapter 3.1 Adjust Maximum Current Output on page 11. If you are unsure of the circuit ratings in your home consult a licensed electrician.

Grizzl-E Duo Intelligent Power Sharing

Grizzl-E Duo features intelligent power sharing to charge two electric vehicles at the same time.

Grizzl-E Duo can provide up to 40A (9.6kW) to one vehicle. If two vehicles are connected and taking maximum power Grizzl-E Duo will supply 50% of the available current to each vehicle.

For more information on Power Sharing between two vehicles see Chapter 7.2 Grizzl-E Duo Intelligent Power Sharing on page 22.

Self-Monitoring and Recovery | Power Outage Recovery

When a charging session is interrupted due to a temporary error condition, the charging station will automatically restart charging when the cause of the temporary error condition returns to normal. Refer to Chapter 6.4 Self-Monitoring and Recovery (Auto Restart) on page 21 for more information.

Product Specifications

Description	Specifications
Model Numbers	GRD-14-24-P; GRD-6-24-P
EVSE Level	SAE J1772; AC Level 2
Max Output Rating	40A Power Sharing; 9.6 kW Maximum Output – For use with 50A Circuit Rating
Alternate Adjustable Output Ratings	32A; 7.68 kW Maximum Output – For use with 40A Circuit Rating 24A; 5.76 kW Maximum Output – For use with 30A Circuit Rating 16A; 3.84 kW Maximum Output – For use with 20A Circuit Rating
Charge Cable Length	24 ft. (7.3m) x2
Electrical Circuit / Input Power Requirements	Dedicated 208VAC Single Phase or 240VAC Split Phase, 50/60 Hz.; Branch Breaker: Double pole; Circuit Conductors: Line 1, Line 2, Earth / Ground
Input Power Connection	Plug-in NEMA 14-50 or Plug-in NEMA 6-50 Not able to be hardwired
Charging Station Color	Standard: Black
Installation Rating	NEMA 4, Indoor/Outdoor Rated
Operational Ratings	Temperature: -22°F to 122°F (-30°C to 50°C); Humidity: 95% RH non-condensing
Mounting	Wall or Pedestal Installation
Overall Dimensions	EVSE: 10.25L x 6.25W x 6.75H inches (26.0 x 16.0 x 17.1 cm)
Display & Indicators	LED Charge Status Indicators (Power/Ready, Charging, Fault)
Cable Management	EasyEvPlug™ with cable management x2
Standards and Compliance	UL Certified. E510712



INSTRUCTIONS Manual

United Chargers GRIZZL-E™ Duo Electric Vehicle Charging Station (EVSE)

Table of Contents

1. Introduction & Unpacking	8
1.1 Your charger	8
1.2 Package Contents	9
2. Installation Planning and Service Wiring:	10
2.1 Electrical Source Requirements	10
2.2 Grounding Instructions	10
2.3 GFCI	10
3. Adjustable Maximum Current	11
3.1 Adjust Maximum Current Output.....	11
4. Installation	14
4.1 Tools & Parts Required for Installation	14
4.2 Install the Charging Station	15
5. EasyEvPlug Holster and Cable Management System	18
6. Charging Status Indicators and Buzzers	19
6.1 Indicator Lights	19
6.2 Grizzl-E Duo Alternating Indicator Light	19
6.3 LED Fault Indicator	20
6.4 Self-Monitoring and Recovery (Auto Restart)	21
6.5 Reset Charger.....	21
7. Operation	22
7.1 Connect and Charge	22
7.2 Grizzl-E Duo Intelligent Power Sharing	22
7.3 Scheduling	23
7.4 Stop Charging	23
7.5 Grizzl-E Duo Output Distribution and Indicator Lights	24
8. General Product Care and Use Information	25
9. Warranty	26

1. Introduction & Unpacking

1.1 Your charger

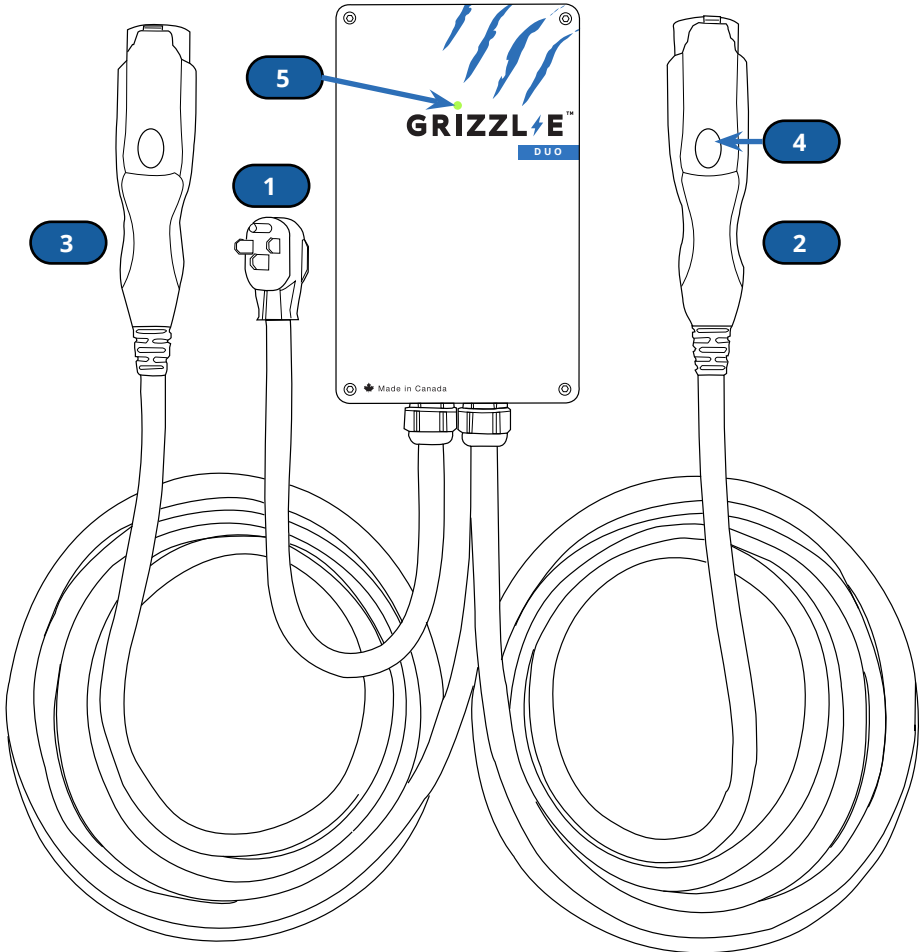

1. Input Cable: NEMA 14-50 or NEMA 6-50
2. J1772 Connector: Primary Charger (Front)
3. J1772 Connector: Secondary Charger (Back)
4. Latch Release Button
5. Indicator Light

1.2 Package Contents

Mounting Kit

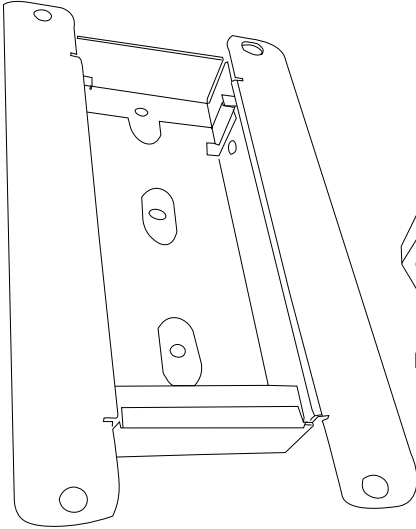

Mounting Bracket (x1)

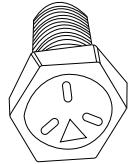

3/8" x 3/4"
Hex-Headed
Bolts (x4)

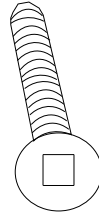

Back Plate
Screws (x2)

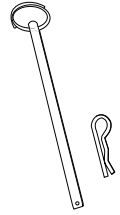

Security Pin (x1)

EasyEvPlug Holster

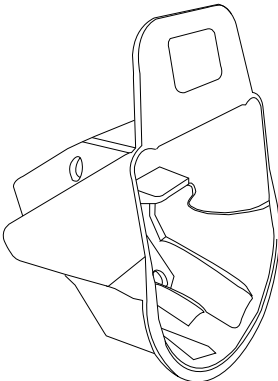

Holster (x2)

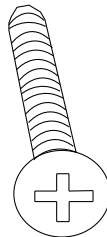

Holster
Screws (x8)

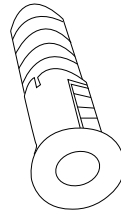

Holster
Anchor (x8)

2. Installation Planning and Service Wiring:



WARNING: Disconnect the power supply to the charging station before installing. Failure to do so may result in physical injury or damage to the power supply system and the charging station.



CAUTION: Connect only to a circuit provided with the minimum branch circuit overcurrent protection requirements in accordance with the National Electrical Code ANSI/NFPA 7- and the Canadian Electrical Safety Code, Part 1, C22.1. Consult a licensed electrician to ensure the circuit meets requirements

2.1 Electrical Source Requirements

- Prior to mounting, locate an available electrical source that can support the following Input Requirements for the Charging Station Per local Electrical Safety Code requirements:
 - » 40A Maximum Output Setting (Default Factory Setting): a DEDICATED CIRCUIT rated for 50A; 208VAC Single Phase or 240VAC Split Phase, 50-60 Hz,
 - » 32A Maximum Output Setting (Default Factory Setting): a DEDICATED CIRCUIT rated for 40A; 208VAC Single Phase or 240VAC Split Phase, 50-60 Hz,
 - » 24A Maximum Output Setting (Default Factory Setting): a DEDICATED CIRCUIT rated for 30A; 208VAC Single Phase or 240VAC Split Phase, 50-60 Hz,
 - » 16A Maximum Output Setting (Default Factory Setting): a DEDICATED CIRCUIT rated for 20A; 208VAC Single Phase or 240VAC Split Phase, 50-60 Hz,
- A Double Pole Circuit Breaker of the circuit rating must be used.
- The Charging Stations can connect a Standard NEMA 6-50 or 14-50 Receptacle. The unit is not able to be hardwired.



Caution: NEMA 14-50 or NEMA 6-50 plug must be used. Do not attempt to disassemble unit to hardwire. Doing so will void the warranty.

2.2 Grounding Instructions

The charging station must be implemented equipment grounding through a permanent wiring system or an equipment grounding conductor. Use a cable with a dedicated grounding conductor connected to the equipment ground terminal block.

2.3 GFCI

- The Charging Unit has a built in GFCI protection; Additional downstream GFCI is not required.
- In locations where GFCI at the outlet is mandated by code, install a 30mA GFCI Breaker. A 5mA GFCI Breaker may cause disruptions to the charger function.

3. Adjustable Maximum Current

The GRIZZLE™ charging station features the ability to adjust the maximum Charging Station current output to support 50A, 40A, 30A, or 20A Dedicated Circuit ratings as follows:

Circuit Rating	Maximum Charging Station Output
50A	40A (9.6 kW)
40A	32A (7.68 kW)
30A	24A (5.76 kW)
20A	16A (3.84 kW)

- The Charging Station Default Factory Maximum Current Output Setting is 40A (9.6 kW) for use with a 50A Circuit Rating.
- The Circuit must be a DEDICATED CIRCUIT 208-240 VAC, 50-60 Hz, Single Phase.
- Requirements govern that only 80% of the circuit rated load may be utilized, hence the higher Circuit Ratings Requirement relative to maximum Charging Station output.

3.1 Adjust Maximum Current Output

To adjust the Maximum Current Output Setting:

1. Ensure unit is unplugged. Secure the Charging Station on a flat surface with the front cover facing out.
2. Remove the front cover by removing the 4 screws at each corner of the charging station.





WARNING: Do not touch live electrical parts. Disconnect the power supply to the charging station before adjusting the DIP Switches. Failure to do so may result in physical injury or damage to the power supply system and the charging station.



CAUTION: The LED pipe is attached to the front cover. When the front cover is removed, place it on a flat surface facing down to avoid damage to the LED pipe.

3. With the front cover placed to the side, locate the DIP switch on the charging station circuit board. The DIP switch is a 4-position switch on the main circuit board, located directly to the left of the LED. Only the DIP Switches on the top board need to be set to change the amperage settings.

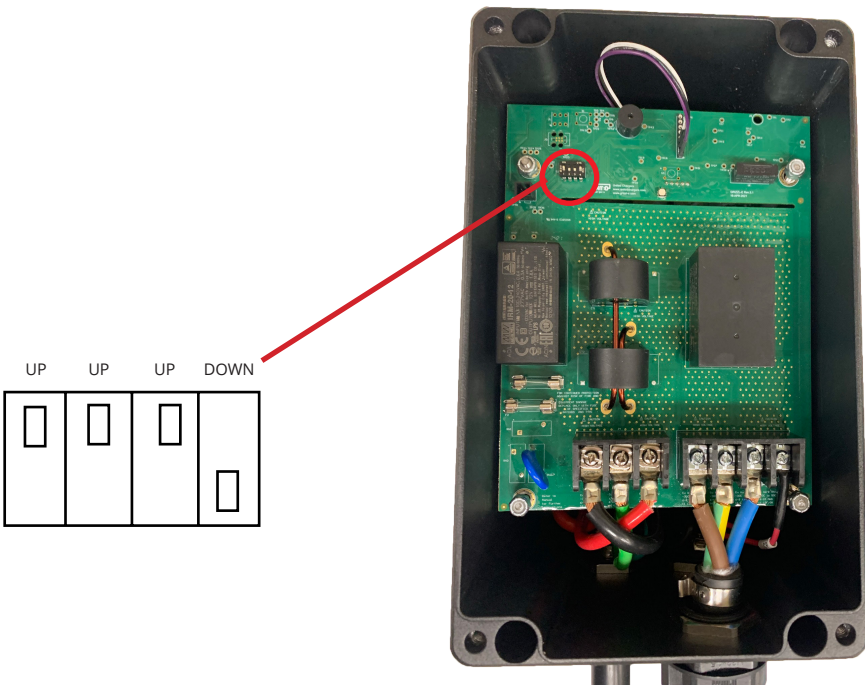



CAUTION: Only the DIP Switches on the top PCB need to be changed to set the maximum amperage settings. Do not attempt to disassemble the unit to access the bottom PCB.

4. Adjust the Maximum Current Output to either 40A, 32A, 24A or 16A, using the following combination of DIP switch settings:

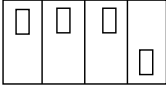
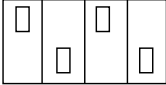
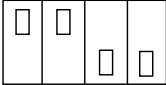
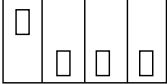
Maximum Current	Switch 1	Switch 2	Switch 3	Switch 4	Diagram
40A Maximum Current Output	UP	UP	UP	DOWN	
32A Maximum Current Output	UP	DOWN	UP	DOWN	
24A Maximum Current Output	UP	UP	DOWN	DOWN	
16A Maximum Current Output	UP	DOWN	DOWN	DOWN	

5. Once the DIP Switch Setting is adjusted, reassemble the charging station. Reinstall the top cover to the charging station using the following torque force to secure the (4) socket cap screw:

Screw	Torque
M6	16 kgf-cm 13.88 lb-in

4. Installation

4.1 Tools & Parts Required for Installation

Prior to mounting, determine the location of an acceptable mounting support. All charging station products must be anchored into a mounting support such as a 2" x 4" stud or a solid concrete wall. **DO NOT** mount this unit directly to a stucco/drywall/wall board.

Tool	Size	Source of Supply	Remark
Mounting Bracket	255 x148 x 36 mm	Included with Product	For mounting the charging station to the wall/structure
Hex-Headed Bolt (x4)	3/8"x 3/4"	Included with Product	For securing the charging station to the Mounting Bracket
Back Plate Screw (x2)	#14	Included with Product	For installing the Mounting Bracket to the wall/structure
Holster/Tesla Holster		Included with Product	To store the EV charging Plug and Cable
Holster Screw (x8)	#8	Included with Product	For installing the EasyEvPlug™ to the wall/structure
Holster Anchors (x8)	#8	Included with Product	For installing the EasyEvPlug™ to the wall/structure
Allen key	M4	Commercially Available	For Charging Station Cover Screws
Hex Wrench	3/4"	Commercially Available	For installing the enclosure plate to the back of the station body.

4.2 Install the Charging Station

1. Separate the front and back piece of the mounting bracket by pushing down on the notch.

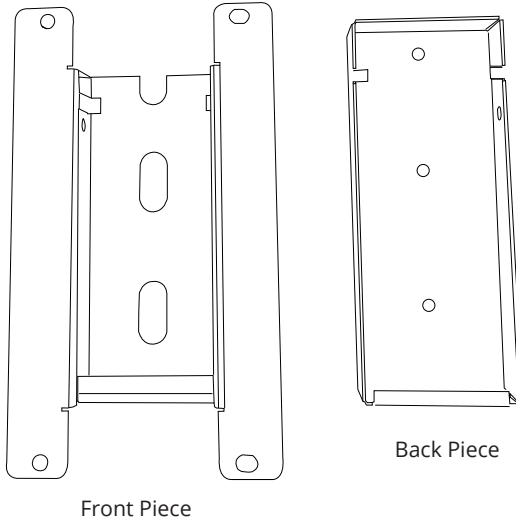

2. Attach the front piece of the mounting bracket to the back of the charging station using the Hex-Headed screws. Ensure the top of the mounting bracket is matched with the top of the charging station.

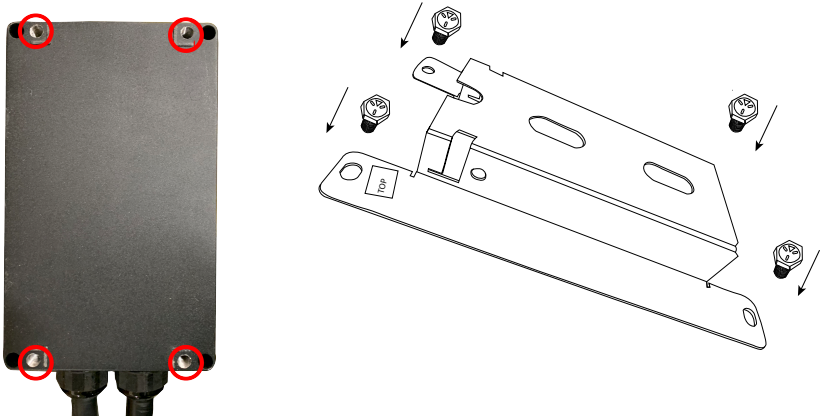

- Secure the back piece of the mounting bracket to the wall or other suitable structure using the Back Plate screws.

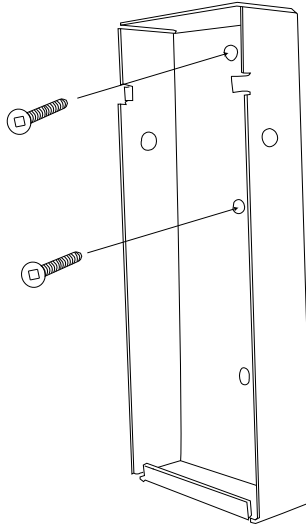

The back piece of the mounting bracket has 3 holes to support attachment to various surfaces. Use the top two holes to attach the mounting bracket to a wall stud.

Mounting Screw Recommendations:

- For finished walls supported by wood studs, use #14 or M6 tapping screws. (Included).
- For masonry walls, use M6 mechanical screws. (Commercially available)
- Use following torque force:

Screw	Torque	
M6	50 kgf-cm	43.4 lb-in
1/4"	50 kgf-cm	43.4 lb-in

Mount the unit at least 18in (460mm) above floor level. The charging station should be less than 24in (610mm) from the NEMA outlet. The NEMA outlet should be located in compliance with all applicable, local electrical safety codes and standards.

4. Mount the charger on the wall by securing the front piece of the mounting bracket to the back piece of the mounting bracket.

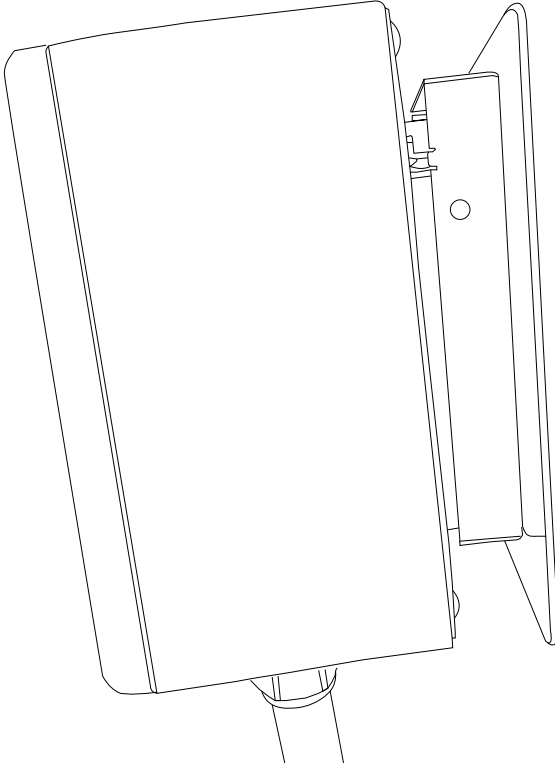

5. Secure the charger in place by inserting either the security pin or the outdoor security lock into the mounting bracket.
6. Plug in Charger to NEMA 14-50 or NEMA 6-50 outlet.

5. EasyEvPlug Holster and Cable Management System

The EasyEVPlug™ Holster or Tesla EasyEVPlug™ Holster is the new innovative method to protect your plug and manage your cord. It has the following features:

- No need to aim – flawless plug even in the dark.
- Your EV holster will always be in a convenient location.
- Saves space – special angle for less wall clearance.
- Integrated cable management – holds up to 25 feet of cable.

The EasyEvPlug holster can be installed at any location near the charging station.

1. Hold back of holster against the mounting surface. Fasten Phillips head screws through back holes. Use anchors if attaching directly to drywall.

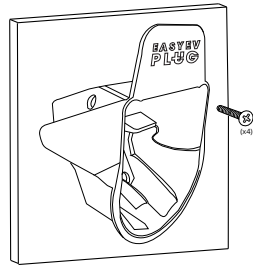

2. Insert charging connector into holster.

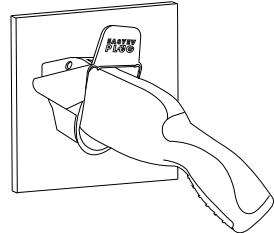



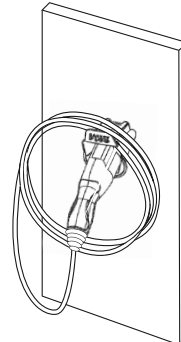





3. Wrap cable on top of EasyEvPlug.



Note: Remove rubber cap from charging gun before inserting into holster. Failure to do so may result in damage to the cap or holster.



6. Charging Status Indicators and Buzzers

6.1 Indicator Lights

LED Indicator	Buzzer	Description	Definition
	No buzzer	Not illuminated	Power Off
	No buzzer	Red Steady	Initialization
	No buzzer	Blue Steady	Ready
	No buzzer	Blue Flashing	Vehicle detected
	No buzzer	Green Flashing	Charging in progress
	No buzzer	Green Steady	Charging complete or no current consumed by the car
	No buzzer	White	Transition (See Chapter 6.2 Grizzl-E Duo Alternating Indicator Light on page 19)
	Buzzer beeps	Red Flashing	Fault (See Chapter 6.3 LED Fault Indicator on page 20)

6.2 Grizzl-E Duo Alternating Indicator Light

Grizzl-E Duo Features an Alternating LED Indicator Light to give the status of both chargers. The primary and secondary charger will display their status in the following sequence:

Primary Charger		Solid Colour or slow flashing indicates the status of the primary charger.	Color: Blue/ Green/Red
Transition		White LED indicates transition of the status Indicator between Primary and Secondary Charger	Color: White
Secondary Charger		Flickering indicates the status of the second charger.	Color: Blue/ Green/Red

See Chapter 7.4 Grizzl-E Duo Output Distribution and Indicator Lights on page 24 for a full list of indicator lights.



6.3 LED Fault Indicator

The number of Red Flashes indicates the charger error:

# of Flashes	Error Description	Primary	Secondary
1	Lost ground - AC	Solid Red	Flickering Red
2	GFCI High	Solid Red	Flickering Red
3	Relay is stuck	Solid Red	Flickering Red
4	GFCI Low	Solid Red	Flickering Red
5	High temperature of the module	Solid Red	Flickering Red
6	High temperature of the relay	Solid Red	Flickering Red
7	Pilot state is Status E	Solid Red	Flickering Red
8	Pilot state is Status F	Solid Red	Flickering Red
9	Diode error	Solid Red	Flickering Red
10	Over Current	Solid Red	Flickering Red
11	No connection with secondary module	Solid Red	N/A
12	Application error	Solid Red	Flickering Red

6.4 Self-Monitoring and Recovery (Auto Restart)

When a charging session is interrupted due to a temporary error condition, it will automatically restart charging when the cause of the temporary error condition returns to normal.

The status indicator lights remain flashing RED, with the number of flashes indicating the error condition, until the error condition is resolved. All error conditions are able to Self-Recover if the error condition is cleared.

The charging session will be stopped when the error condition occurs. The charger will self-monitor the error condition for 60 seconds. If the error condition is cleared the charger will take an additional 60 seconds to automatically reset. If the error condition is not cleared the charger will continue to display a RED error light.

If the error condition occurs within 5 seconds of the start of a charging session a permanent fault will trigger.

6.5 Reset Charger

In the instance of a fault remains, it is recommended that you:

1. Unplug the charging Connector from your EV
2. Turn off the power to the Charging Station by switching the upstream circuit breaker to the "OFF" position
3. With the circuit breaker in the "OFF" position, wait 1-2 minutes and then switch the upstream circuit breaker back to the "ON" position
4. Confirm that the Fault light is no longer present. If the Fault light remains, fill out the [Technical Support Form](#). Indicate the number of flashes.

7. Operation

7.1 Connect and Charge

Insert one of the charging connectors into the EV and ensure the connector is fully seated/locked in place. Once complete, the charging session will begin.

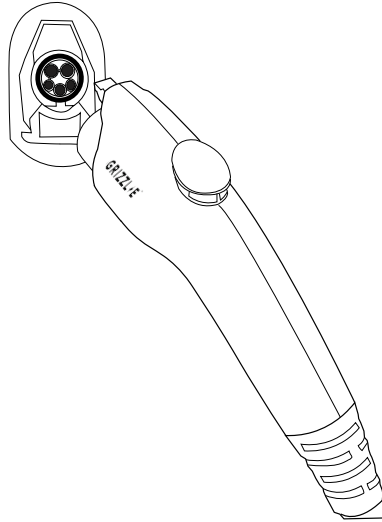

7.2 Grizzl-E Duo Intelligent Power Sharing

Grizzl-E Duo features intelligent power sharing to charge two electric vehicles at the same time.

Grizzl-E Duo's power sharing algorithm shares amperage between two vehicles in the following manner:

1. If one vehicle is connected to Duo, then the maximum amperage (40A,32A, 24A,16A based on DIP Switch settings) is available for this vehicle.
2. If two vehicles are connected, then the maximum available amperage is divided evenly between the two vehicles (Example: $40A / 2 = 20A$ for each vehicle).
3. If two vehicles are connected and one vehicle goes to state 'Charging Complete', then 8A is dedicated to the completed vehicle. The remainder of the amperage is available for the other vehicle (Example: $40A - 8A = 32A$).
4. If both vehicles are completed 8A are available for both vehicles. If one completed vehicle goes to a Charging state again, then 32A will be available for this vehicle. If the second vehicle goes to a Charging State the amperage will gradually split 50/50 again.

See Chapter 7.4 Grizzl-E Duo Output Distribution and Indicator Lights on page 24 for a full list of power distribution and indicator lights.



7.3 Scheduling

Grizzl-E Duo power sharing algorithm may experience compatibility issues with certain types of vehicle charging schedules.

When setting a schedule on the vehicle for Grizzl-E Duo:

- Only use “Time schedules” that start charging at a certain time.
- When charging two vehicle it is advised to begin both charging sessions at the same time.
- Do not use a schedule that charges based on battery percentage. This may cause the charger to display an error.

7.4 Stop Charging

1. Press down on the latch release button. Ensure latch release button is fully compressed.
2. Remove the Charger Connector from the EV
3. Return the connector to the holster.

7.5 Grizzl-E Duo Output Distribution and Indicator Lights

The following Table shows the behavior and indicator lights of the Grizzl-E Duo:

Charging Status	Output Distribution	LED Indicator
No Vehicle No Vehicle	0% 0%	Blue Solid Blue Flickering
Vehicle Detected* No Vehicle	100% Available 0%	Blue Flashing Blue Flickering
Charging No Vehicle	100% 0%	Green Flashing Blue Flickering
Charging Complete No Vehicle	8A Available 0%	Green Solid Blue Flickering
No Vehicle Vehicle Detected	0% 100% Available	Blue Solid Blue Flickering + Flashing
Vehicle Detected Vehicle Detected	50% Available 50% Available	Blue - Flashing Blue Flickering + Flashing
Charging Vehicle Detected	50% 50% Available	Green Flashing Blue Flickering + Flashing
Charging Complete Vehicle Detected	8A Available 100% - 8A Available	Green Solid Blue Flickering + Flashing
No Vehicle Charging	0% 100%	Blue Solid Green Flickering + Flashing
Vehicle Detected Charging	50% Available 50%	Blue Flashing Green Flickering + Flashing
Charging Charging	50% 50%	Green Flashing Green Flickering + Flashing
Charging Complete Charging	8A Available 100% - 8A	Green Solid Green Flickering + Flashing
No Vehicle Charging Complete	0% 8A Available	Blue Solid Green Flickering
Vehicle Detected Charging Complete	100% - 8A Available 8A Available	Blue Flashing Green Flickering
Charging Charging Complete	100% - 8A 8A Available	Green Flashing Green Flickering
Charging Complete Charging Complete	8A Available 8A Available	Green Solid Green Flickering

*Vehicle detected occurs when the EV is plugged into the charger but is not ready to accept energy. This usually happens when there is a charging schedule on the vehicle.



8. General Product Care and Use Information

The exterior of the charging station is designed to be waterproof and dust proof (NEMA 4 Outdoor Rated). However, periodic cleaning may be required, depending on local conditions. To ensure proper maintenance of the charging station, follow these guidelines:

- To avoid damaging the finish of the products, only use an automotive grade soft cleaning cloth with soap and water to remove accumulated dirt and dust. Do not use cleaning solvents to clean any of the product components.
- Despite the water resistance of the enclosure, submerging the unit in water is not recommended.
- Ensure the charging connector is put back in the holster after charging to avoid damage.
- Ensure the power cable is stored on the charging station after use to avoid damage.
- Do not hang the charging gun upside down with the cap on outdoors, as water may accumulate in the cap. This may cause oxidation which leads to a blue residue on the connectors.
- If the power cable or the charging connector is damaged, turn off the charging station supply circuit breaker, do not use the charging station, and Contact United Chargers Customer Support for replacement parts.
- When moving or lifting the unit, always grasp and carry by the charging station body. Never attempt to lift, move, or carry the unit by any of the electrical cables. Improper handling may cause damage to the unit.



9. Warranty

GRIZZL-E™ Duo EV Residential Charging Stations 3 Years Replacement Warranty.

This warranty is extended by United Chargers to original purchasers of GRIZZL-E™ Duo EV Charging Stations. United Chargers warrants that this product is free from defects in materials years and free from defects in workmanship for the period specified in the warranty from the date of purchase. If during the Warranty Period, under normal operating conditions, your charging station becomes defective, United Chargers will, upon written notice of the defect, replace the charging station until the defect is resolved.

This warranty will not apply if the product has been misused, abused, or altered. The warranty does not cover cosmetic damage such as scratches, dents, or normal aging. The warranty does not cover damage as a result of an extreme power surge, extreme electromagnetic field, or any acts of nature. This warranty will not apply if the product is used and connected to any adapter and/or extension cable. The warranty for the cable does not include normal tear and wear. Plugs that have been exposed to snow or water for a prolonged period of time are not covered by this warranty. The waterproof rating of the enclosure cannot be guaranteed if the charger is mounted upside down. The warranty will apply only if the product is defective.

United Chargers assumes no liability for any dismantling, removal, installation, re-installation, or labour costs or any consequential damages associated with this warranty. United Chargers is not responsible or liable for any costs associated with faulty installations. United Chargers shall make the final decision, in fairness to all concerned, as to the legitimacy of any such claim on this warranty.

Upon discovery of any defective GRIZZL-E™, please visit our Technical Support page for further instructions as to how to repair or replace the defective unit or to submit a support ticket.

United Chargers Inc

25 Pollard St,

Richmond Hill, ON, Canada, L4B 1A8

Phone: +1-833-971-8118

E-mail: info@unitedchargers.com

Website: www.grizzl-e.com

Visit our Technical Support page:

<https://autochargers.zendesk.com/hc/en-ca>

View the full terms and conditions:

<https://grizzl-e.com/policies/>

The most up to date User Manual is available online at:

<https://grizzl-e.com/manuals/>